

Electronic Warning and Command Unit

K - SM 10

BN 5020/11 -/12

Operation Manual

Table of contents

| | page | |
|-----------|--|----|
| 1 | Scope of supply | 2 |
| 2 | General | 3 |
| 3 | Control units | 4 |
| 3.1 | Overview and functions | 4 |
| 3.2 | Priorities | 5 |
| 3.4 | Signal control | 6 |
| 4 | Overall Dimensions | 7 |
| 4.1 | Built in configuration | 7 |
| 4.2 | Built up configuration | 8 |
| 5 | Loudspeaker installation | 9 |
| 5.1 | Overall Dimensions of K-SR 30 | 10 |
| 5.2 | Overall Dimensions of K-SR 51 | 11 |
| 5.3 | Overall Dimensions of K-SR 71 | 12 |
| 6 | Block diagram K-SM 10 | 13 |
| 7 | Installation | 14 |
| 7.1 | Pin designation K-SM 10 | 14 |
| 7.2 | Connection diagram with 2 loudspeakers | 15 |
| 7.3 | Connection diagram with 1 loudspeaker | 16 |
| 7.4 | Connection diagram with TOPas - lightbar | 17 |
| 7.5 | Pin designation microphone | 18 |
| 8 | Safety precautions | 19 |
| 9 | Technical data K-SM 10 | 20 |
| A1 | Changing defective halogen bulbs in the TOPas- lightbar | 23 |

1 Scope of supply

1.1 K-SM 10 in-dash configuration

BN 5020 / 11

- K-SM 10
- Microphone incl. holder clip
- 1 x Molex-connector 12 pins incl. inserts
- 2 x Molex-connector 3 pins incl. inserts
- Operating Manual

BN 5020 / 00.01

BN 5020 / 00.85

1.1 K-SM 10 on-dash configuration

BN 5020 / 12

- K-SM 10
- Microphone incl. holder clip
- 1 x Molex-connector 12 pins incl. inserts
- 2 x Molex-connector 3 pins incl. inserts
- Operating Manual

BN 5020 / 00.01

BN 5020 / 00.85

1.3 Loudspeaker

1.3.1 K - SR 30 (30 watt system)

BN 5030 / 01

1.3.2 K - SR 51 (50 watt system)

BN 5031 / 01

1.3.3 K - SR 71 (70 watt system)

BN 5033 / 01

1.3 Options

1.3.1 Vehicle cable assembly K-ZKA 10

BN 5020 / 00.05

1.3.2 Optional transformer for loudspeakers

BN 5020 / 00.11

2 General

2.1 Prerequisites

2.1.1 Vehicle

There has to be a 12V power supply, battery minus to ground.

2.1.2 K-SM 10

Check that all components are available.

2.2 Installation

Before installation the battery minus has to be disconnected. Connect the minus-pole after implementation of the installation.

Pay attention for the right polarity and fuses !

- | | |
|--|------------|
| – switched battery-plus, ignition lock | - clamp 15 |
| – battery - plus | - clamp 30 |
| – battery - minus | - clamp 31 |
| – vehicle ground, connected to battery minus | - ⊥ |

Use for all connections AMP or similar contacts.

2.3 Color code of cables

| | | | | | | | | |
|----|---|--------|----|---|--------|-------|---|-------------|
| bl | - | blue | or | - | orange | wh | - | white |
| bn | - | brown | pk | - | pink | wh/bn | - | white/brown |
| ye | - | yellow | rd | - | red | wh/gn | - | white/green |
| gn | - | green | bk | - | black | wh/bk | - | white/black |
| gy | - | grey | vt | - | violet | | | |

3 Control Units

3.1 Frontview

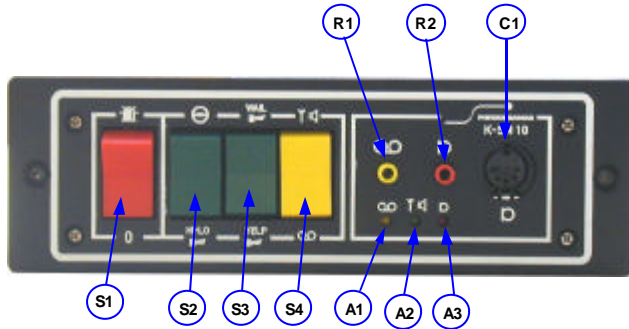

| Pos. | Function |
|------|---------------------------|
| S1 | Beacon ON |
| S2 | PEAK / HI-LO |
| S3 | WAIL / YELP |
| S4 | Broadcast / Tape |
| A1 | Indicator Tape ON |
| A2 | Indicator Broadcast ON |
| A3 | Indicator Microphone ON |
| R1 | Volume control Tape |
| R2 | Volume control Microphone |
| C1 | Microphone Connector |

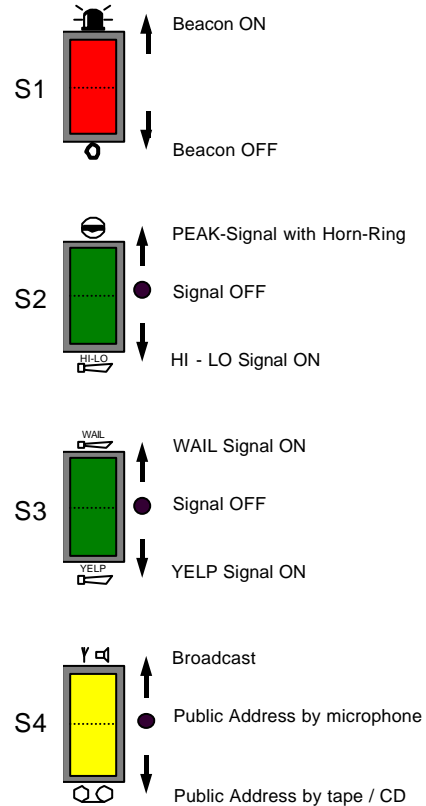

3.2 Priorities

The priority of signals are:



3.4 Signal control

Standard:

By selecting "PEAK", the signal is activated by pressing the horn-ring. The signal is active as long as the horn-ring is pushed. After releasing the signal will decrease gradually.

The signals "WAIL", "YELP" and "HI-LO" are activated by selecting the corresponding switch.

By pressing the horn-ring while "WAIL" or "YELP" is activated, the signal is changing to the other one.

By pressing the horn-ring while "HI-LO" is activated, the signal "AIRHORN" is activated until the horn-ring will be released.

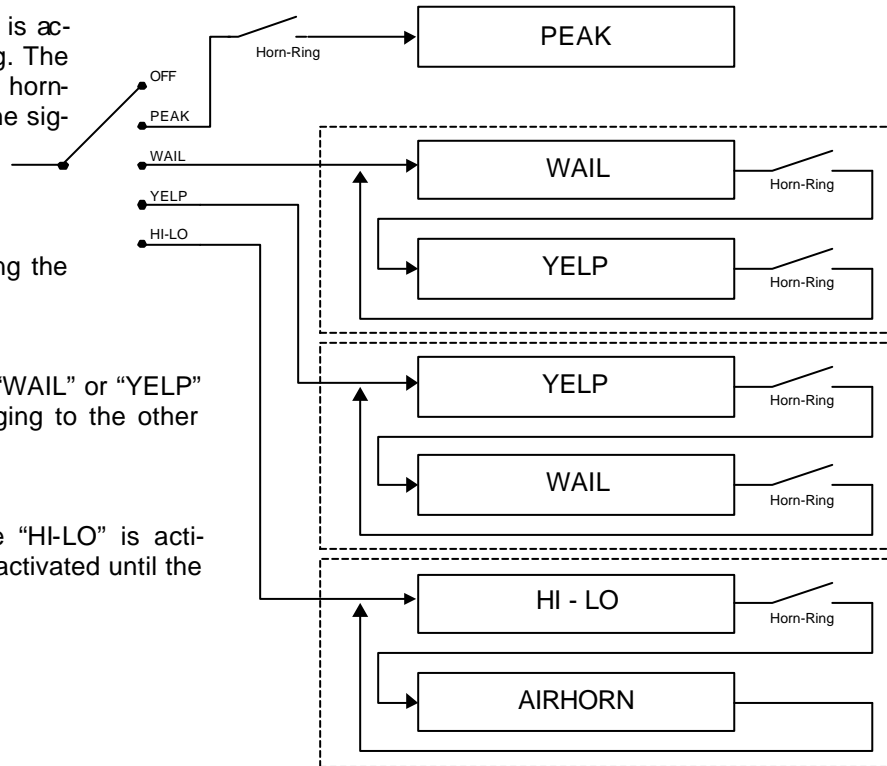

4 Overall Dimensions K - SM 10

4.1 In-dash configuration (e.g. broadcast / tape support)

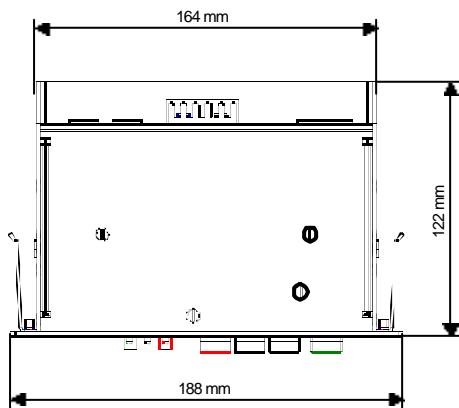

bottom view

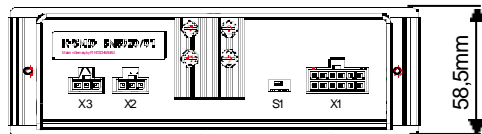

back view

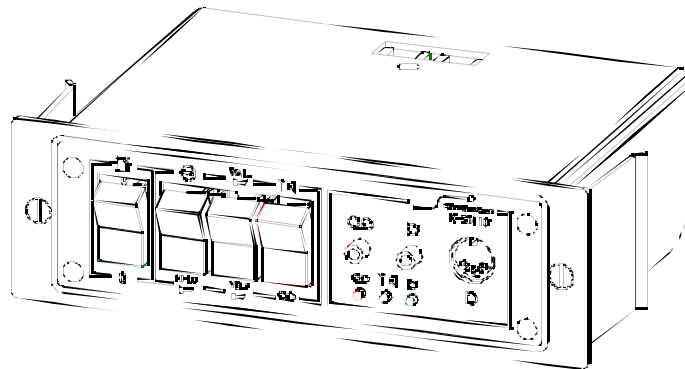

4.2 On-dash configuration (e.g. on / below dashboard)

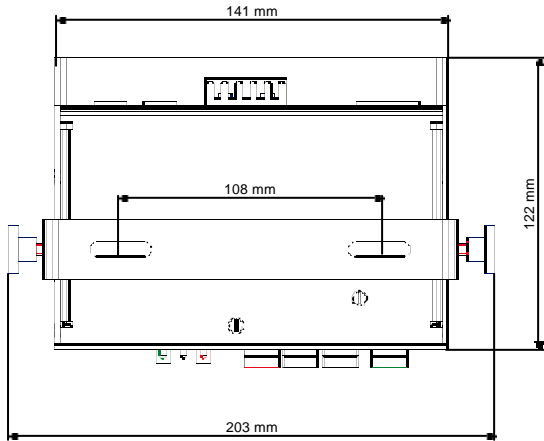

bottom view

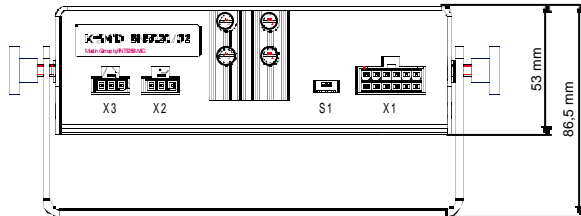
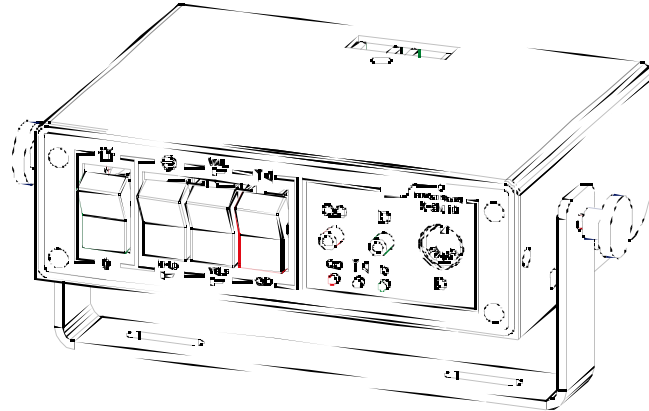

back view

5. Loudspeaker installation

- The Loudspeakers have to be installed in such a way, that the sound-wave hit the ground in approx. 30m distance.

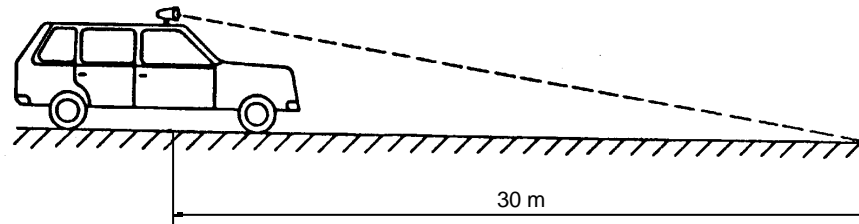

- The loudspeaker location has to be as far as possible at the front of the vehicle.
- By installing two loudspeakers, pay attention to the phase of both speakers !
- The maximum torque of the mounting-screws are 6 Nm.

5.1 Overall Dimensions K - SR 30

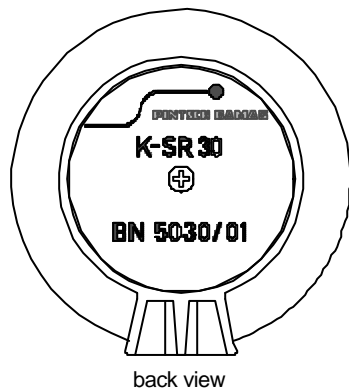
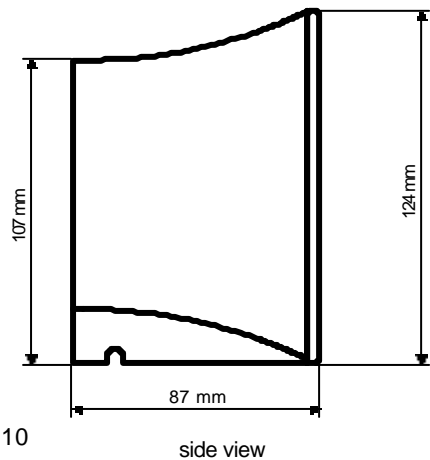
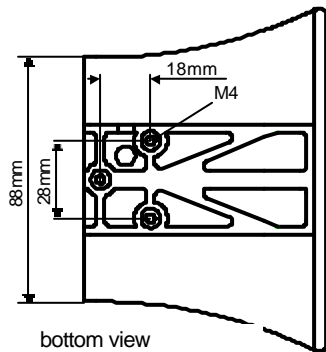

5.2 Overall Dimensions K - SR 51

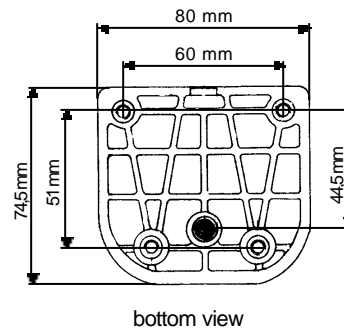
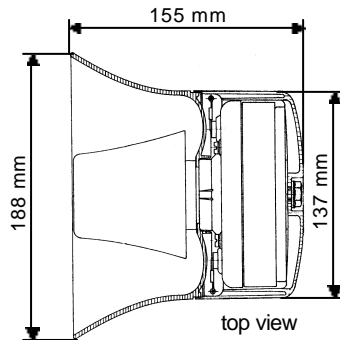
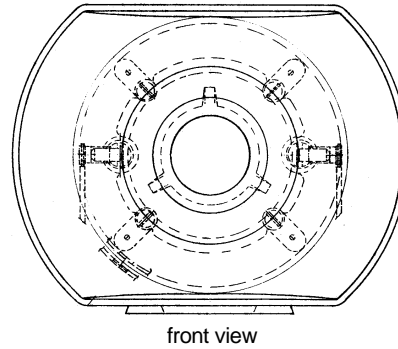
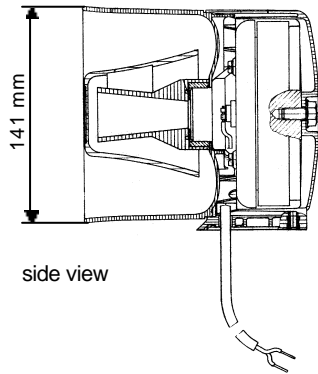

5.3 Overall Dimensions K - SR 71

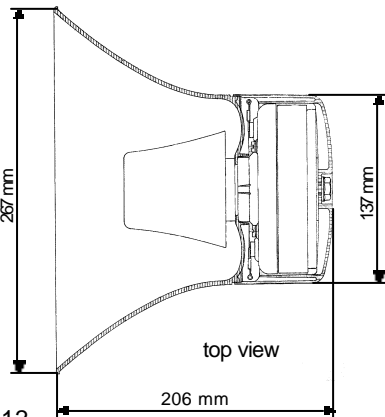
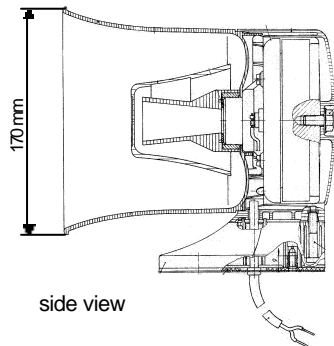

front view

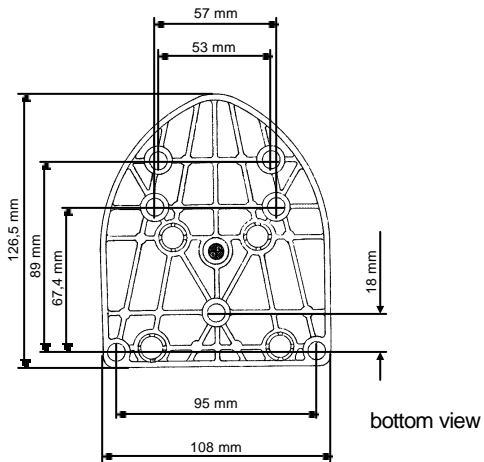
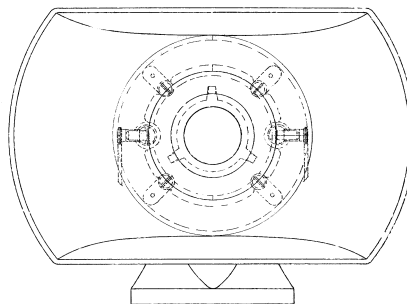

6 Block diagram K - SM 10

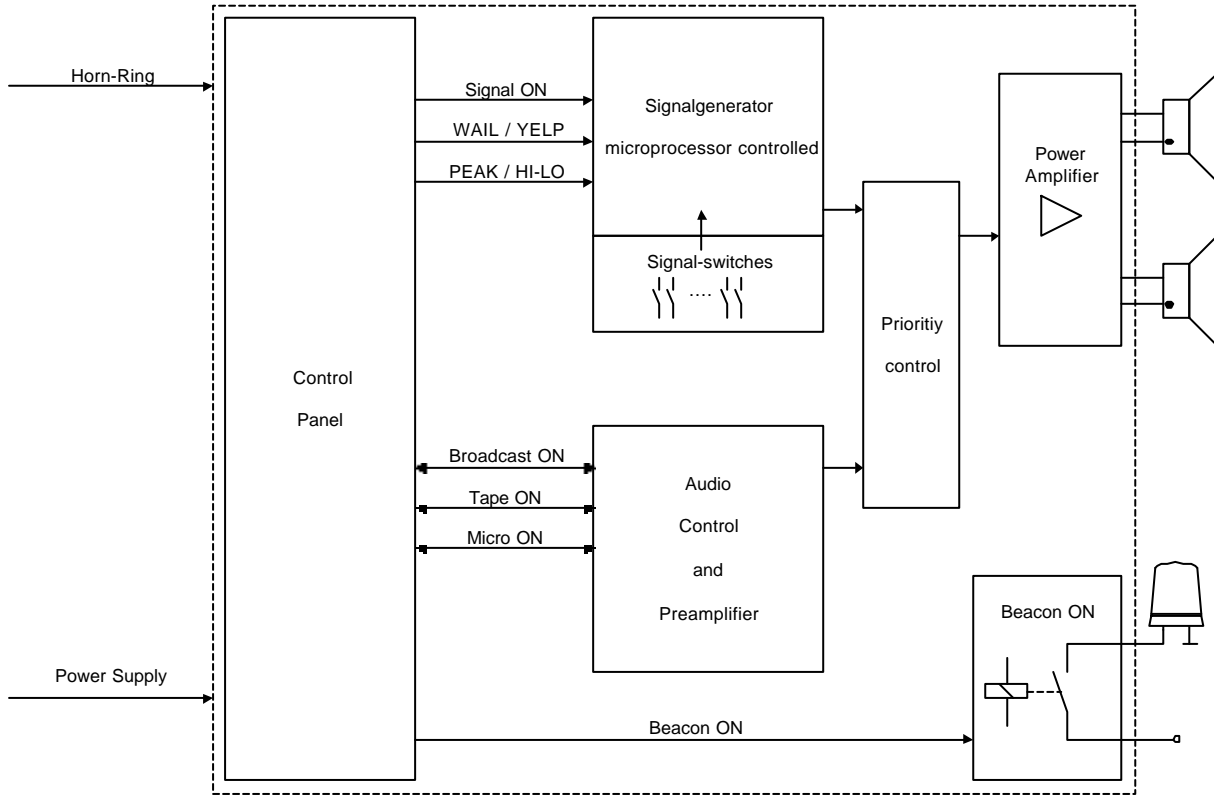

7 Installation

7.1 Pin designation

X 3

Broadcast



| Pin | Function |
|-----|---------------|
| 1 | not connected |
| 2 | AF-Screen |
| 3 | AF-Signal |

X 2

Tape



| Pin | Function |
|-----|---------------|
| 1 | AF-Signal |
| 2 | AF-Screen |
| 3 | not connected |

SW1

Horn-Ring
standard minus

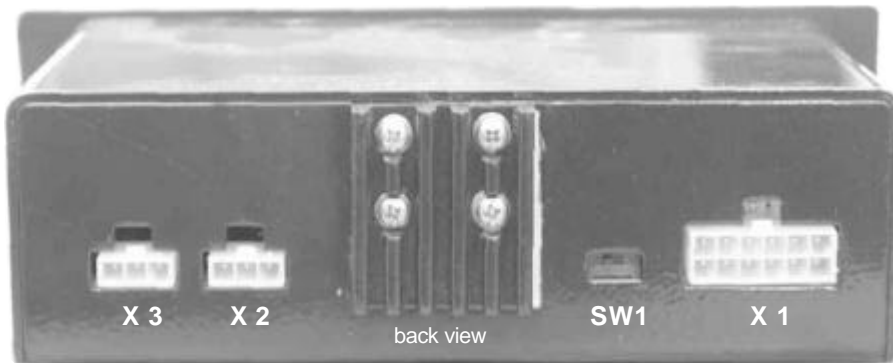
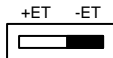

back view

X 1

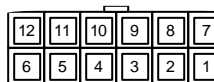

| Pin | Function | Pin | Function |
|-----|-----------------|-----|-----------------|
| 1 | Battery minus | 7 | Horn-Ring |
| 2 | Loudspeaker 1/1 | 8 | Loudspeaker 2/1 |
| 3 | Loudspeaker 1/2 | 9 | Loudspeaker 2/2 |
| 4 | Battery plus | 10 | |
| 5 | Beacon 1/1 | 11 | Beacon 1/2 |
| 6 | Beacon 2/1 | 12 | Beacon 2/2 |

7.2 Connection Diagram with K-SR30, K-SR51 or K-SR71

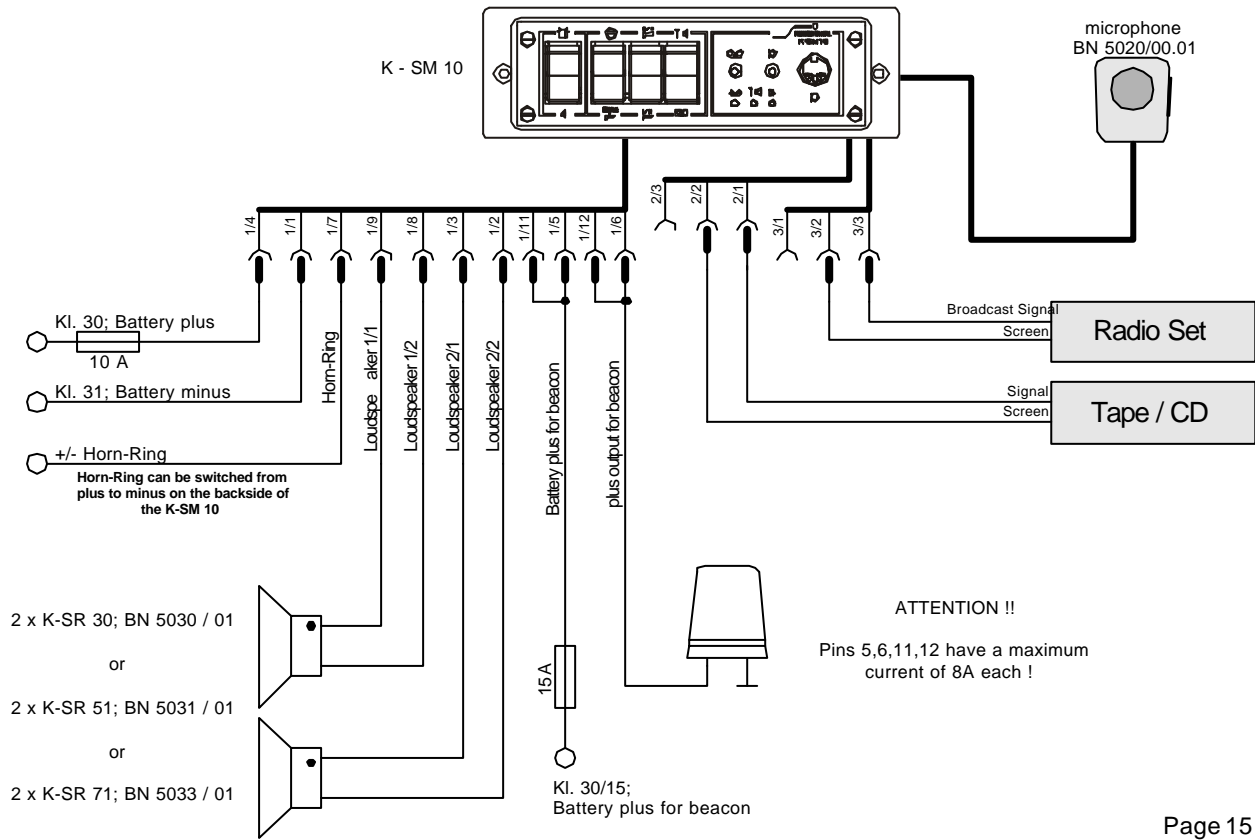

7.3 Connection diagram with one loudspeaker K-SR71

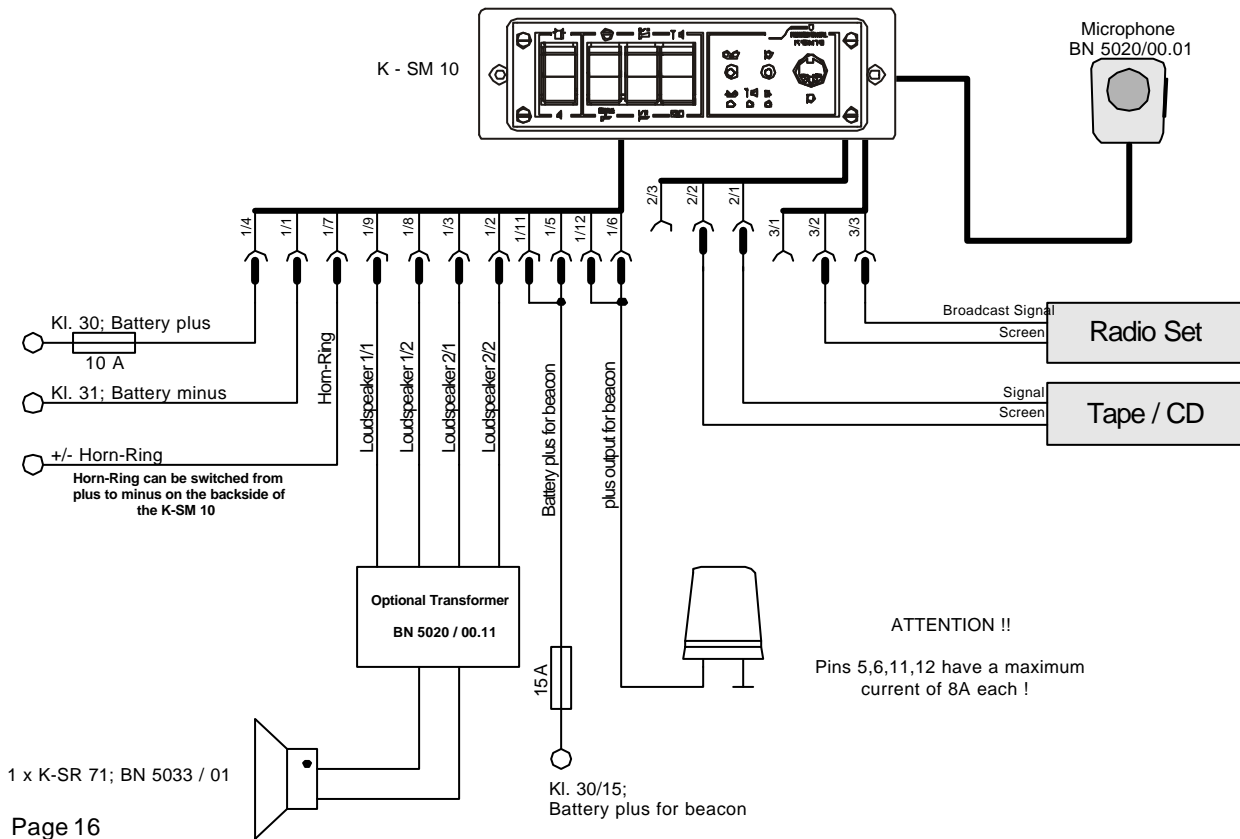

1 x K-SR 71; BN 5033 / 01

7.4 Connection diagram for TOPasLightbar

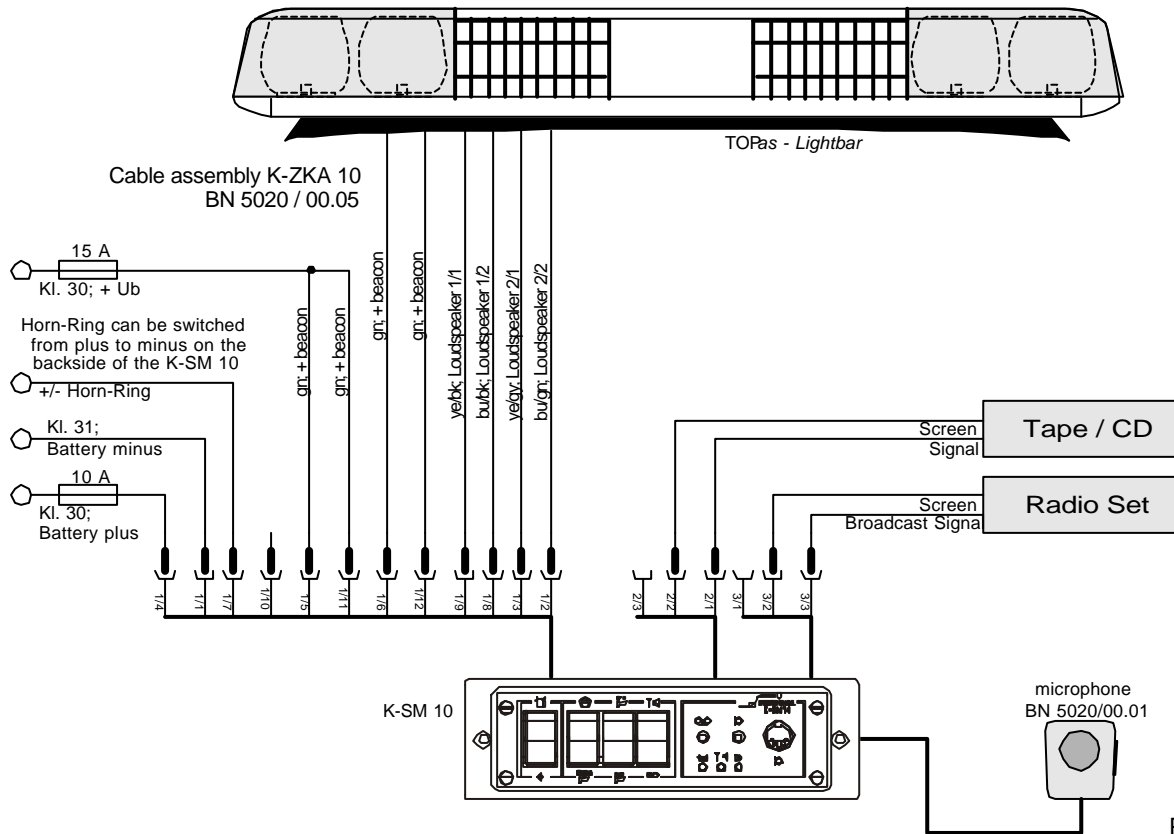

7.5 Pin designation Microphone-connector

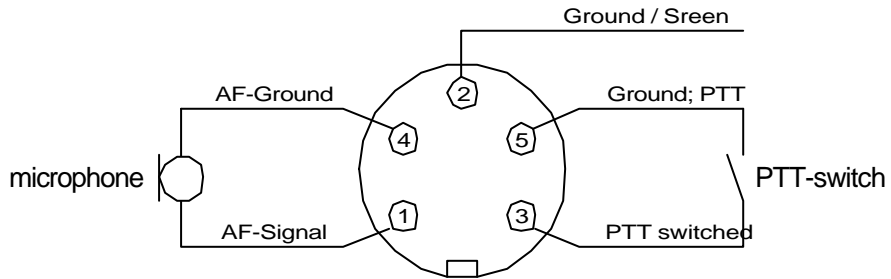

The added microphone has to be used ! (BN 5020 / 00.01)

8 Safety precautions

8.1 Liability

The K-SM 10 includes international signal-characteristics. National regulations have to be taken in consideration. The user is liable by using unauthorized signals.

8.2 Power supply

The voltage and polarity of the vehicle batteries shall be in compliance with the K-SM 10 requirements.

8.3 Fuses

Only specified fuses are allowed.

8.4 Failures and uncommon stress

In case the equipment is unsafe to operate, it has to be replaced to avoid harm to any person.

This can be if the equipment is

- damaged.
- malfunctioning.

8.5 Repairing and changing parts

All repairs are to be implemented by authorized and skilled personal only.

No modification is allowed that will degrade the safety.

Only original spare parts have to be used.

9. Technical data K-SM 10

| | | | | |
|--|----------|------------------|--------------------------------|-------------------------|
| <u>Power supply</u> | | | <u>Inputs / Outputs</u> | |
| Operation voltage | | 12 V-DC | -> Microphone | 8 mV / 500 Ω |
| Operation voltage range | 10,8 ... | 14,4 V-DC | -> Broadcast | 3,2 V / 10 K Ω |
| Power consumption | | | -> Tape / CD | 775 mV / 3 K Ω |
| Stand by | | <1 mA | -> Horn-Ring | |
| Maximum | | 6 A | <- Beacon | max. 16 A |
| <u>Environmental conditions</u> | | | Output peak power | 80 W |
| Ambient temperature | | | <u>Warning signal</u> | |
| Operating range | | -25°C ... +60°C | | PEAK, HI-LO, WAIL, YELP |
| Storage and shipment | | -40°C ... +85°C | | |
| <u>Mechanical data</u> | | | | |
| Dimensions (h x w x d in mm) | | | | |
| in-dash configuration | | 58,5 x 188 x 122 | | |
| on-dash configuration | | 53 x 141 x 122 | | |
| Weight (in g) | | | | |
| in-dash configuration | | 750 g | | |
| on-dash configuration | | 750 g | | |

APPENDIX

A1 Changing defective halogen-bulbs

1. Loosen Screws by using a mm Allen key



2. Remove domes

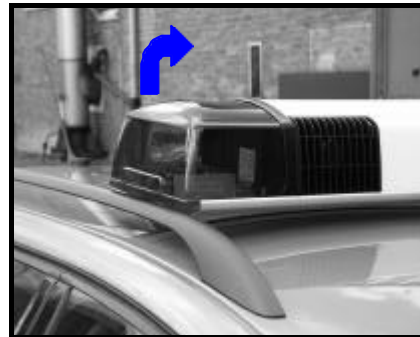

3. Remove fastening clip

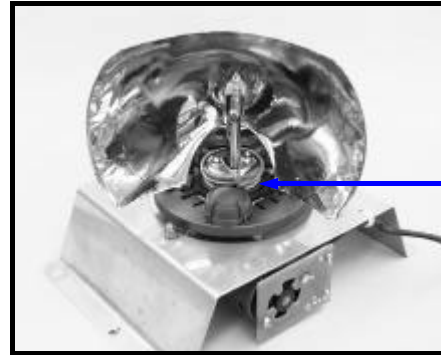

4. Pull out defective halogen-bulb



5. Insert new bulb and fix fastening-clip



**6. Put on beacon-dome and fix with torque
maximum = 2 Nm**



Notes

Notes



Address: Hünxer Strasse 149
D-46537 Dinslaken

PO.BOX 10 04 20
D-46524 Dinslaken

Phone : +49 2064 / 602 - 327

FAX : +49 2064 / 602 - 283