

Electromagnetic Two-Disc Spring-Set Brake SFB-SH

Increased brake torque

PINTSCH BAMAG
DINSLAKEN

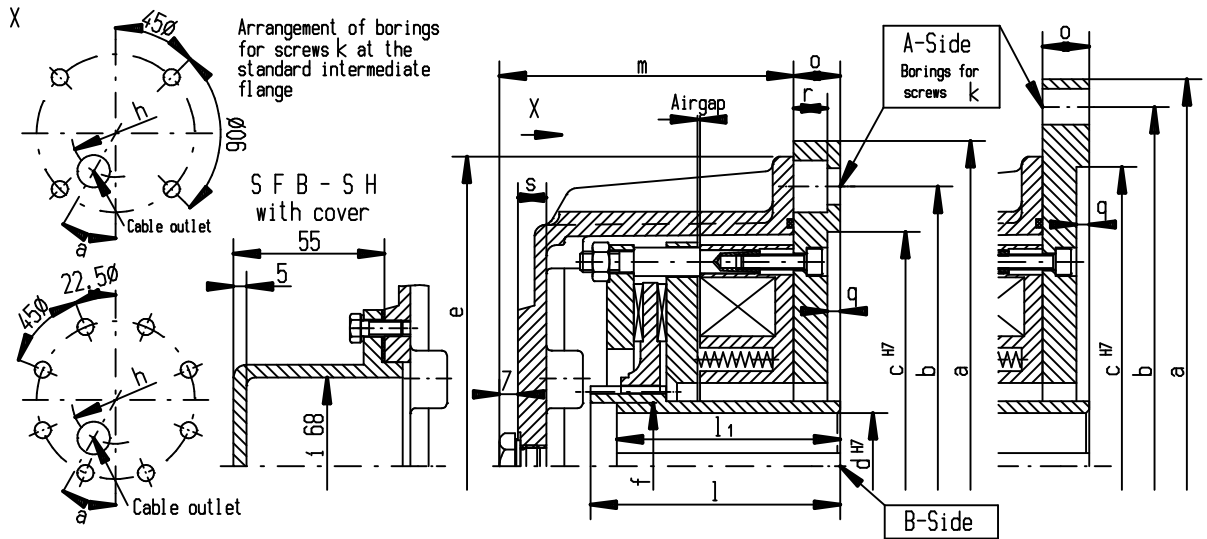

Heftung sowie Verwendung dieser Literatur, Verwertung und Mitteilung ihres Inhaltes nicht gestattet.
 Sondernur für den Fall der Beauftragung der Pintsch Bamag - Maschinenbau AG, Dinslaken 1881.
 speziell nicht ausdrücklich zugelassen. Zusicherungen verpflichten zu

Brake size		S F B 6.3-SH	S F B 10-SH	S F B 16-SH	S F B 25-SH	S F B 40-SH	S F B 63-SH	S F B 100-SH	S F B 160-SH	S F B 250-SH				
Brake torque M2 dynamic acc. to DIN VDE 0580	Nm	80	130	210	350	550	800	1300	2100	3300				
		75	120	190	310	490	750	1200	1900	3000				
		69	110	180	275	440	690	1100	1750	2750				
Mass moment of inertia	kgm ²	0.0017	0.0037	0.0048	0.0068	0.0175	0.036	0.050	0.128	0.140				
Mass (weight)	kg	19	28	42	55	74	106	168	242	306				
max. speed	min ⁻¹	6000	6000	6000	5500	4700	4000	3600	3200	2800				
Coil b. 200C	Nominal voltage	V DC	110	110	110	110	110	110	110	110				
	Nominal power	W	99	128	158	196	220	307	344	435				
	Nominal current	A	0.90	1.16	1.44	1.78	2.0	2.79	3.13	3.95	4.50			
Airgap, brake OFF	minimal mm	0.3	0.3	0.3	0.4	0.4	0.4	0.6	0.4	0.4				
	maximal mm	0.9	1.2	1.2	1.3	1.4	1.8	1.8	2.3	2.5				
Diameter mm	B-Side	d Rough boring	26	26	36	36	36	36	36	46	46			
		d H7 Preferential boring	28	28	38	38	48	60	60	65	65			
			32	32	42	42	55	65	65	70	70			
			38	38	48	48	60	75	75	75	75			
		d H7 maximal	40	40	55	55	60	75	75	90	90			
e	238	260	280	318	400	440	446	540	556					
Lengths mm	f					95	95	128	128					
	h	150	180	202	214	244	292	330	394	440				
	l	96	96	117	117	142	148	148	191	191				
	l ₁	96	96	117	117	142	142	142	171	171				
	m	115	118	137	143	169	171	183	211	232				
	s	11	11	11	12	14	15	15	15	15				
	α°	15	15	30	22.5	30	30	30	30	45				
Suitable standard Intermediate flange	A250	A300	A300-1	A350	A400	A400-1	A450-1	A450-1	A550-1	A660				
	A300	A350	A350	A400	A450	A450	A660	A660	A800	A800				
Dimensions of standard intermediate flanges														
Dia- meter mm	Standard intermediate flange		A250	A300	A300-1	A350	A400	A400-1	A450	A450-1	A550	A550-1	A660	A800
	a		250	300	300	350	400	400	450	450	550	550	660	800
	b		215	265	265	300	350	350	400	400	500	500	600	740
	c H7		180	230	230	250	300	300	350	350	450	450	550	680
	o		18	18	18	20	22	22	24	24	24	24	30	30
	q		5	5	5	6	6	6	6	6	6	6	7	7
Lengths mm	r		13	13				17.5		17.5		17.5		
	Screws k		4xM12	4xM12	4xM12	4xM16	4xM16	4xM16	8xM16	8xM16	8xM16	8xM16	8xM20	8xM20

Keyways for keys acc. to DIN 6885/1, width accuracy P9
Protection IP 67

Subject to modifications in dimension and construction

Datum 25.03.2003	erstellt Tho	gezeichnet	geprüft Thonen	normgeprüft	Erz.: 214	Blatt von	01 02
ΩM-NR.	Tag	Name	a01 231 800-953				

Electromagnetic Two-Disc Spring-Set Brake SFB-SH Increased brake torque

PINTSCH BAMAG
DINSLAKEN

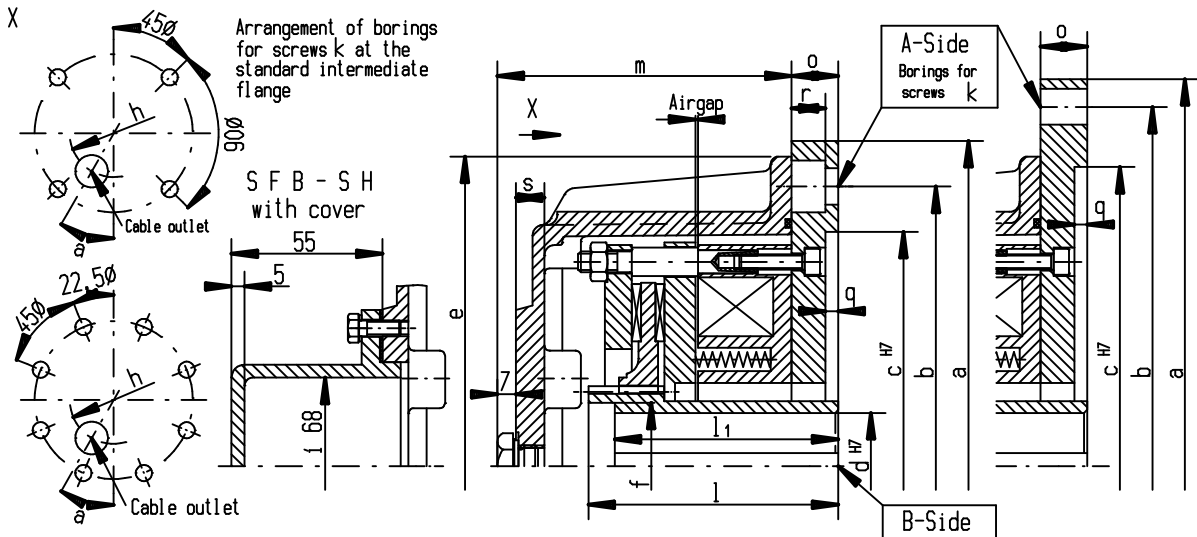

speziell nicht ausdrücklich zugelassen. Zusicherungen verpflichten zu...
 © PINTSCH BAMAG Antrieb- und Hydraulik GmbH, Dinslaken 1981.
 Weitergabe sowie Herstellung dieser Unterlagen, Vermehrung und Mitteilung ihres Inhaltes nicht gestattet.
 Schutzantrag. Die Rechte an den in der Dokumentation der Erfindung enthaltenen Erfindungsgegenständen vorbehalten.

Brake size		SFB 400-SH	SFB 630-SH	SFB 1000-SH						
Brake torque M2 dynamic acc. to DIN VDE 0580 Nm		5200 4800 4400	8000 7500 6900	13000						
Mass moment of inertia kgm ²		0.325	0.375	1.007						
Mass (weight) kg		357	500	750						
max. speed min ⁻¹		2500	2200	2000						
Coil b. 200C	Nominal voltage V DC	110	110	110						
	Nominal power W	553	671	980						
	Nominal current A	5.03	6.10	8.91						
Airgap, brake OFF		minimal mm	0.4	0.7	0.7					
		maximal mm	2.5	2.8	3.1					
Diameter mm	B-Side	d Rough boring	46	58	68					
		d H7 Preferential boring	65	100	125					
			70							
			75							
			80							
		d H7 maximal	110	125	140					
e	660	700	795							
f	128	140	155							
h	520	570	620							
Lengths mm	l	191	237	282						
	l ₁	171	210	255						
	m	272	310	360						
	s	15	15	15						
	α°	30	30	30						
Suitable standard intermediate flange		A660-1	A800	A800-1						
		A800								

Dimensions of standard intermediate flanges

Standard intermediate flange		A660-1	A800	A800-1						
Dia- meter mm	a	660	800	800						
	b	600	740	740						
	c H7	550	680	680						
Lengths mm	o	30	30	30						
	q	7	7	7						
	r	21.5		21.5						
	Screws k	8xM20	8xM20	8xM20						

Keyways for key acc. to DIN 6885/1, width accuracy P9
Protection IP 67

Subject to modifications in dimension and construction

Datum 25.03.2003	erstellt Tho	gezeichnet	geprüft Thonen	normgeprüft	Erz.: 214	Blatt von	02 02
QM-NR.					a01 231 800-953		
Tag							
Name							