

**Spare part list**  
**Electromagnetic Spring-Set-Brake**  
**Series KFB 160**

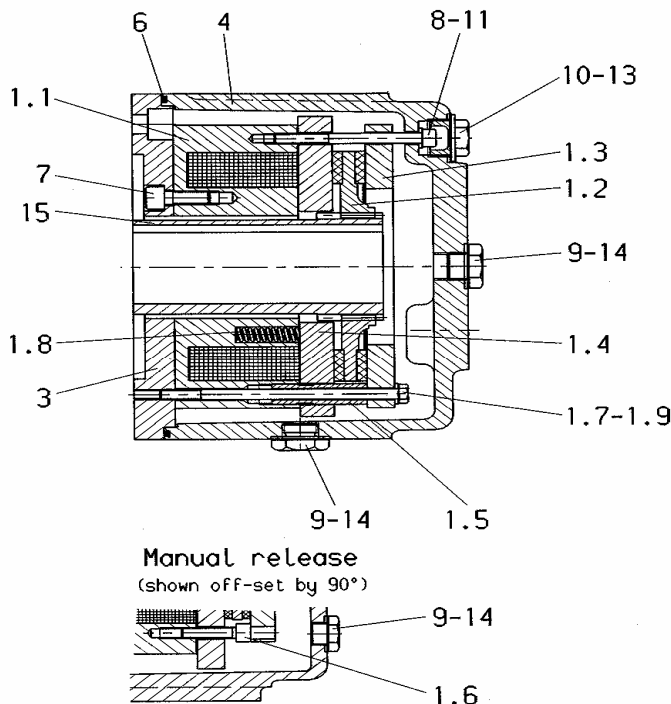

**Please supply the following details when ordering**

**spare parts:**

- Dimension of the brake (type)
- Brake serial number
- Description of the spare part
- Quantity required
- Id.-No. of the spare part

Type, serial number of the brake and the coil voltage are specified on the rating plate.

Rating plate

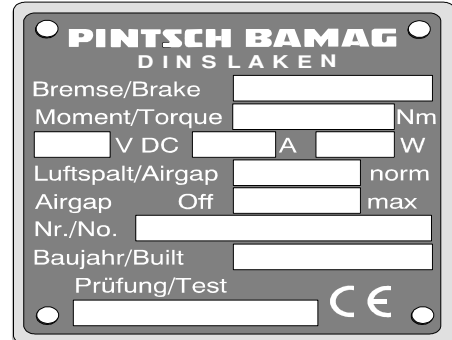

)* pos.	description	qty.	dimension / standard	P.B. Id.-No.
X 1.1	coil body group	1	voltage see rating plate	type specific
1.2	friction lining group	1	D 318/d 110 x 42 22 teeth	000 581 701-214
1.3	brake flange	1	D 388/d 230 x 22,5	001 222 000-214
X 1.4.1	armature plate	1	D 398/d 157 x 28	001 221 800-214
X 1.4.2	armature plate group f. 1MS/PS	1	D 398/d 157 x 28	001 221 900-214
X 1.4.3	armature plate group f. 2MS/PS	1	D 398/d 157 x 28	001 221 910-214
1.5	adjusting bolt	3	D 30/M 30x1,5 x 91	001 222 100-214
1.6	socket head screw TUF-LOC	2	M 10x50 / ISO 4762	031 411 844-000
1.7	hexagon screw	3	M 16x160 / ISO 4014	031 021 884-200
1.8	pressure spring	32	D 16 x 71	047 010 016-012
1.9				not available
X 3.0.1	adaptor flange	1	standard flange A450	001 222 200-214
X 3.0.2		1	standard flange A550	001 222 300-214
X 3.0.3		1	special flange	type specific
X 4.0.1	housing	1	normal housing A450	001 220 200-214
X 4.0.3		1	special housing	type specific
X 6.0.1	O-ring f. housing A450	1	420 x 5 NBR	042 572 850-100
7	socket head screw	12	M 12x30 / ISO 4762	031 411 604-200
8	socket head screw	3	M 8x100 / ISO 4762	031 411 149-200
9	lock bolt	6	M 16x1,5 / DIN 7604	032 410 210-000
10	lock bolt	3	M 26x1,5 / DIN 7604	032 410 220-100
11	washer	3	B 8,4 / DIN 9021-140HV-A2	037 038 326-000
13	sealing ring	3	A 26x31 / DIN 7603	042 524 097-200
14	sealing ring	6	A 16x20 / DIN 7603	042 524 064-000
X 15	hub (pinion)	1		type specific

)\*: For ordering spare parts marked with X, please specify the serial number of the brake printed on the rating plate.

**Note:** Positions with three digits (f.e. 1.2.3) are possible variants. The installed variant depends on the type of the brake.

**Additional equipment:** To order spare parts for additional equipment like lever for manual release, side-fitting connection box, micro- or proximity switch, it is necessary to specify the serial number of the brake.

Datum 23.03.2007	erstellt VK/Thonen	geprüft VK / THO	ÄM-Nr. C / 4-Tho07032	<b>a01 220 000-958</b>
---------------------	-----------------------	---------------------	--------------------------	------------------------