

**Spare part list  
Electromagnetic Spring-Set-Brake  
Series KFB 30**

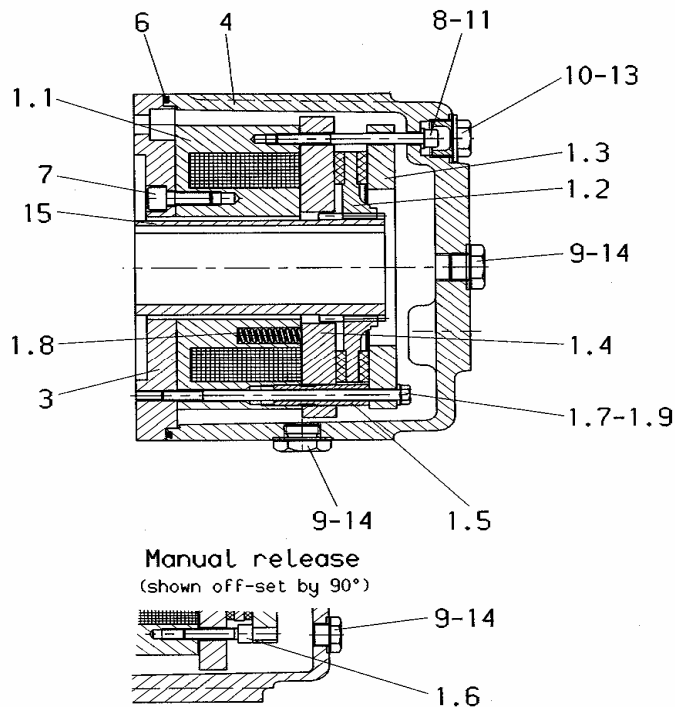

**Please supply the following details when ordering spare parts:**

- Dimension of the brake (type)
- Brake serial number
- Description of the spare part
- Quantity required
- Id.-No. of the spare part

Type, serial number of the brake and the coil voltage are specified on the rating plate.

Rating plate

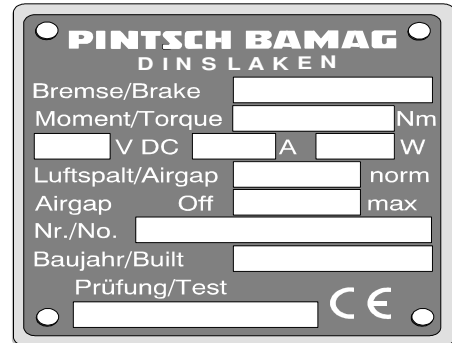

)* pos.	description	qty.	dimension / standard	P.B. Id.-No.
X 1.1	coil body group	1	voltage see rating plate	<i>type specific</i>
1.2	friction lining group	1	D 173/d 59 x 20 20 teeth	001 176 300-214
1.3	brake flange	1	D 214/d 108 x 13	001 175 600-214
X 1.4.1	armature plate	1	D 222/d 66 x 17	001 177 600-214
X 1.4.2	armature plate group f. 1MS/PS	1	D 222/d 66 x 17	001 177 700-214
X 1.4.3	armature plate group f. 2MS/PS	1	D 222/d 66 x 17	001 177 800-214
1.5	adjusting bolt	3	D 18/M 18x1 x 50	001 176 200-214
1.6	socket head screw TUF-LOC	2	M 6x40 / ISO 4762	031 411 782-200
1.7	hexagon screw	3	M 10x130 / ISO 4014	031 021 484-100
1.8	pressure spring	12	D 16 x 71	047 010 016-012
1.9	circlip	3	VSKD 10 / BN 208012	037 424 130-000
X 3.0.1	adaptor flange	1	standard flange A250	001 226 600-214
X 3.0.2		1	standard flange A300	001 229 000-214
X 3.0.4		1	special flange	<i>type specific</i>
X 4.0.1	housing	1	normal type A250	001 211 900-214
X 4.0.2		1	normal type A300	001 228 800-214
X 4.0.3		1	special housing	<i>type specific</i>
X 6.0.1	O-ring f. housing A250	1	230 x 3 NBR	042 572 432-100
X 6.0.2	O-ring f. housing A300	1	280 x 3 NBR	042 572 509-200
7	socket head screw	7	M 8x25 / ISO 4762	031 411 128-200
8	socket head screw	3	M 8x70 / ISO 4762	031 411 144-200
9	lock bolt	6	M 16x1,5 / DIN 7604	032 410 210-000
10	lock bolt	3	M 26x1,5 / DIN 7604	032 410 220-100
11	washer	3	B 8,4 / DIN 9021-140HV-A2	037 038 326-000
13	sealing ring	3	A 26x31 / DIN 7603	042 524 097-200
14	sealing ring	6	A 16x20 / DIN 7603	042 524 064-000
X 15	hub (pinion)	1		<i>type specific</i>

)\*: For ordering spare parts marked with X, please specify the serial number of the brake printed on the rating plate.

**Note:** Positions with three digits (f.e. 1.2.3) are possible variants. The installed variant depends on the type of the brake.

**Additional equipment:** To order spare parts for additional equipment like lever for manual release, side-fitting connection box, micro- or proximity switch, it is necessary to specify the serial number of the brake.

Datum 23.03.2007	erstellt VK/Thonen	geprüft VK / THO	ÄM-Nr. B / 4-Tho07032	<b>a01 213 000-958</b>
---------------------	-----------------------	---------------------	--------------------------	------------------------