

**Spare part list  
Electromagnetic Spring-Set-Brake  
Series KFB 16**

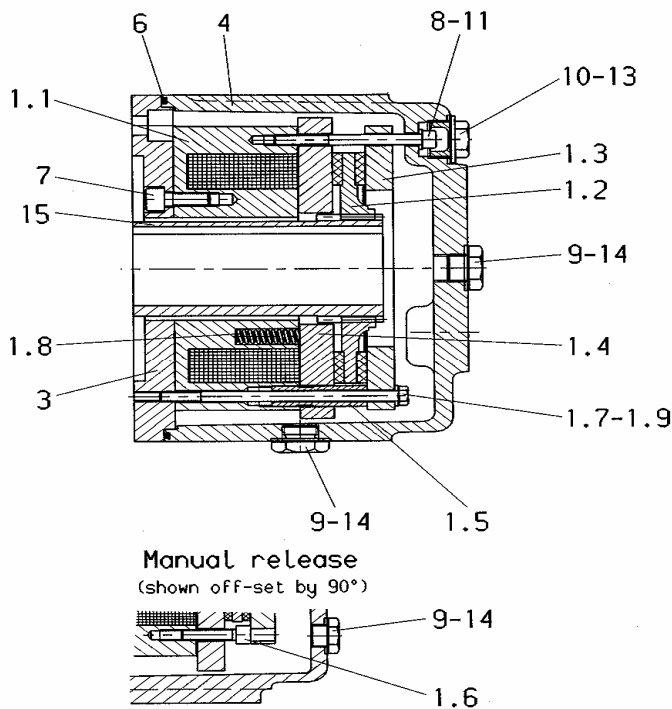

**Please supply the following details when ordering spare parts:**

- Dimension of the brake (type)
- Brake serial number
- Description of the spare part
- Quantity required
- Id.-No. of the spare part

Type, serial number of the brake and the coil voltage are specified on the rating plate.

Rating plate

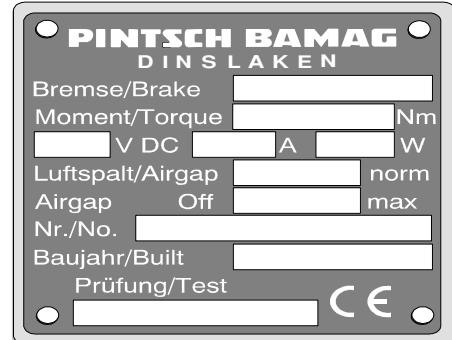

)* pos.	description	qty.	dimension / standard	P.B. Id.-No.
X 1.1	coil body group	1	voltage see rating plate	<i>type specific</i>
1.2	friction lining group	1	D 165/d 56 x 16 19 teeth	000 798 100-214
1.3	brake flange	1	D 200/d 106 x 12	001 065 900-214
X 1.4.1	armature plate	1	D 220/d 72 x 13	001 068 000-214
X 1.4.2	armature plate group f. 1MS/PS	1	D 220/d 72 x 13	001 195 900-214
X 1.4.3	armature plate group f. 2MS/PS	1	D 220/d 72 x 13	001 196 000-214
1.5	adjusting bolt	3	D 14/M 14x1 x 42,5	001 062 700-214
1.6	socket head screw TUF-LOC	2	M 6x30 / ISO 4762	031 411 778-200
1.7	hexagon screw	3	M 6x95 / ISO 4014	031 021 640-100
1.8	pressure spring	16	D 11 x 36	047 010 011-005
1.9	circlip	3	VSKD 6 / BN 208012	037 424 126-000
X 3.0.1	adaptor flange	1	standard flange A250	001 068 200-214
X 3.0.2		1	standard flange A300	001 068 100-214
X 3.0.3		1	standard flange A350	001 224 000-214
X 3.0.4		1	special flange	<i>type specific</i>
X 4.0.1	housing	1	normal type A250	001 065 600-214
X 4.0.2		1	normal type A300	001 065 700-214
X 4.0.3		1	special housing	<i>type specific</i>
X 6.0.1	O-ring f. housing A250	1	228 x 4 NBR	042 572 429-000
X 6.0.2	O-ring f. housing A300	1	280 x 4 NBR	042 572 510-100
7	socket head screw	6	M 10x20 / ISO 4762	031 411 162-000
8	socket head screw	3	M 6x60 / ISO 4762	031 411 114-000
9	lock bolt	4	M 16x1,5 / DIN 7604	032 410 210-000
10	lock bolt	5	M 22x1,5 / DIN 7604	032 410 214-000
11	washer	3	B 6,4 / DIN 9021-140HV-A2	037 038 320-000
13	sealing ring	5	A 22x29 / DIN 7603	042 524 088-000
14	sealing ring	4	A 16x20 / DIN 7603	042 524 064-000
X 15	hub (pinion)	1		<i>type specific</i>

)\*: For ordering spare parts marked with X, please specify the serial number of the brake printed on the rating plate.

**Note:** Positions with three digits (f.e. 1.2.3) are possible variants. The installed variant depends on the type of the brake.

**Additional equipment:** To order spare parts for additional equipment like lever for manual release, side-fitting connection box, micro- or proximity switch, it is necessary to specify the serial number of the brake.

Datum 23.03.2007	erstellt VK/Thonen	geprüft VK / THO	ÄM-Nr. C / 4-Tho07032	<b>a01 076 200-958</b>
---------------------	-----------------------	---------------------	--------------------------	------------------------