

**Spare part list**  
**Electromagnetic Spring-Set-Brake**  
**Series SFB 1000**



**Please supply the following details when ordering spare parts:**

- Dimension of the brake (type)
- Brake serial number
- Description of the spare part
- Quantity required
- Id.-No. of the spare part

Type, serial number of the brake and the coil voltage are specified on the rating plate.

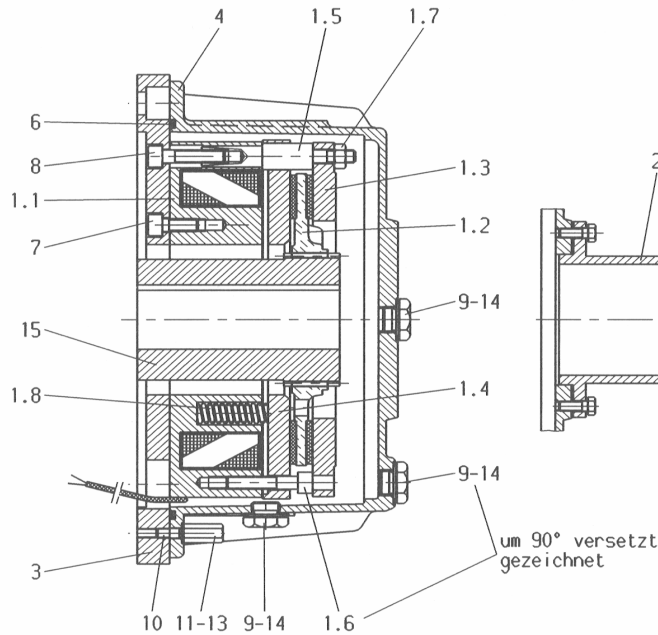

Rating plate

<b>PINTSCH BAMAG</b>	
D I N S L A K E N	
Bremse/Brake	<input type="text"/>
Moment/Torque	<input type="text"/> Nm
<input type="text"/> V DC	<input type="text"/> A <input type="text"/> W
Luftspalt/Airgap	<input type="text"/> norm
Airgap	Off <input type="text"/> max
Nr./No.	<input type="text"/>
Baujahr/Built	<input type="text"/>
Prüfung/Test	<input type="text"/>

)*	pos.	description	qty.	dimension / standard	Kg/piece	P.B. Id.-No.
X	1.1.1	coil body group 110V DC	1	110 V DC		001 047 800-214
X	1.1.2	coil body group				type specific
	1.2	friction lining group	1			000 617 500-214
	1.3	brake flange	1			000 617 800-214
X	1.4.1	armature plate	1			000 617 600-214
X	1.4.2	armature plate group f. 1 MS/PS				
X	1.4.3	armature plate group f. 2 MS/PS				
	1.5	bolt	12			000 618 000-214
	1.6	socket head screw	2	M 16 x 90 DIN 912 L.W.		031 411 924-000
	1.7	self-locking hexagon nut	12	VM 24 DIN 980		035 075 793-000
	1.8	pressure spring	74	D 23,7 x 91,8		047 010 023-003
	2.0					
X	3.0.1	adaptor flange	1	standard flange A800	90,00	000 618 600-214
X	3.0.2			special flange		type specific
X	4.0.1	housing	1			000 617 700-214
X	4.0.2			special housing		type specific
	6	O-ring	1	610 x 7		027 010 450-000
	7	socket head screw	4	M 16 x 35 DIN 912		031 411 290-000
	8	socket head screw	12	M 16 x 80 DIN 912		031 410 778-000
	9	lock bolt	6	AM 22 x 1,5 DIN 7604		032 410 214-000
	10	stud	12	M12 x 40 DIN 939		033 030 158-000
	11	cup nut	12	M 12		007 032 200-248
	13	washer	12	A12 x 18 DIN 7603		042 524 054-000
	14	washer	6	A22 x 29 DIN 7603		042 524 088-000
	15.1	hub (pinion)	1	rough drilled D=68		000 618 800-214
	15.2	hub (pinion)		standard cylindrical		type specific

)\*: For ordering spare parts marked with X, please specify the serial number of the brake printed on the rating plate.

**Note:** Positions with three digits (f.e. 1.2.3) are possible variants. The installed variant depends on the type of the brake.

**Additional equipment:** To order spare parts for additional equipment like side-fitting connection box, micro- or proximity switch, it is necessary to specify the serial number of the brake.

Datum 26.09.2003	erstellt EVA / Thonen	geprüft EVA / Tho	ÄM-Nr. A / 4-Tho03078	<b>a00 617 100-958</b>
---------------------	--------------------------	----------------------	--------------------------	------------------------