

**Spare part list  
Electromagnetic Spring-Set-Brake  
Series SFB 25**



**Please supply the following details when ordering spare parts:**

- Dimension of the brake (type)
- Brake serial number
- Description of the spare part
- Quantity required
- Id.-No. of the spare part

Type, serial number of the brake and the coil voltage are specified on the rating plate.

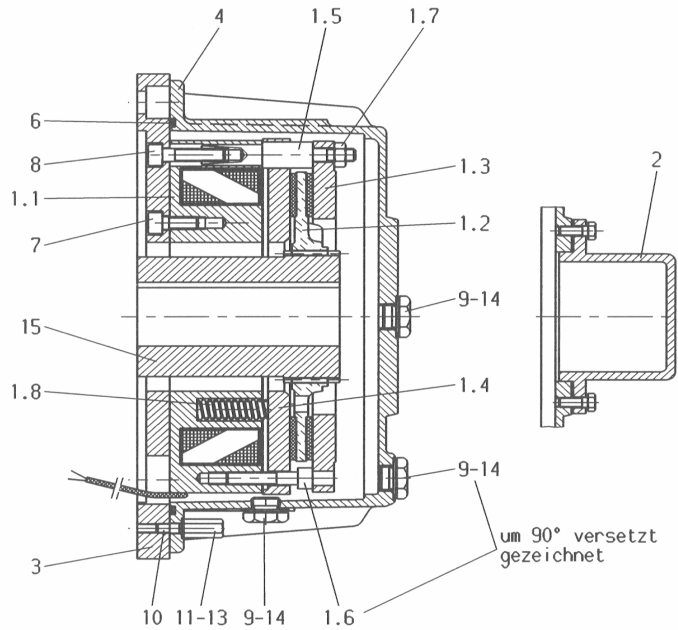

Rating plate

<b>PINTSCH BAMAG</b>		D I N S L A K E N	
Bremse/Brake	[ ]		
Moment/Torque	[ ]	Nm	
[ ] V DC	[ ] A	[ ] W	
Luftspalt/Airgap	[ ]	norm	
Airgap	Off	[ ]	max
Nr./No.	[ ]		
Baujahr/Built	[ ]		
Prüfung/Test	[ ]		
		CE	

)* pos.	description	qty.	dimension / standard	Kg/piece	P.B. Id.-No.
X 1.1.1	coil body group 110V DC	1	D=235 D=97 x 56 110V DC	13,50	000 594 500-214
X 1.1.2	coil body group		D=235 D=97 x 56	13,50	type specific
1.2	friction lining group	1	D 196/d 76 x 25 19z	0,80	000 594 600-214
1.3	brake flange	1	D 237/d 133 x 14,5	2,80	000 595 300-214
X 1.4.1	armature plate	1	D 237/d 97 x 17,2	4,60	000 594 900-214
X 1.4.2	armature plate group f. 1 MS/PS		D 237/d 97 x 17,2	4,60	001 153 400-214
X 1.4.3	armature plate group f. 2 MS/PS		D 237/d 97 x 17,2	4,60	001 153 401-214
1.5	bolt	4	D 16x 98 M10	0,40	000 595 500-214
1.6	socket head screw	2	M 8 x 40 DIN 912 L.W.		031 411 803-000
1.7	self-locking hexagon nut	4	VM 10 DIN 980		035 075 772-000
1.8	pressure spring	16	D 12,4 x 48		047 010 012-009
2.0	cover group	1	D 120 x 65		269 300 004-000
X 3.0.1	adaptor flange	1	standard flange A350	11,50	000 595 100-214
X 3.0.2			standard flange A400	16,50	000 595 200-214
X 3.0.3			standard flange A450	23,20	000 659 200-214
X 3.0.4			special flange		type specific
X 4.0.1	housing	1	D 318 x 134	9,50	000 595 800-214
X 4.0.2			special housing		type specific
6	O-ring	1	250 x 4		042 572 498-000
7	socket head screw	4	M 8 x 20 DIN 912		031 411 126-000
8	socket head screw	4	M 8 x 35 DIN 912		031 411 532-000
9	lock bolt	6	AM 16 x 1,5 DIN 7604		032 410 210-000
10	stud	6	M8 x 18 DIN 939		033 020 784-000
11	cup nut	6	M8 x 29		035 620 957-001
13	washer	6	A8 x 14 DIN 7603		042 524 036-000
14	washer	6	A16 x 20 DIN 7603		042 524 064-000
15.1	hub (pinion)	1	rough drilled D=36	3,80	000 594 700-214
15.2	hub (pinion)		standard cylindrical		type specific
16	anti condensation heater	1	230V AC		001 041 900-214

)\*: For ordering spare parts marked with X, please specify the serial number of the brake printed on the rating plate.

**Note:** Positions with three digits (f.e. 1.2.3) are possible variants. The installed variant depends on the type of the brake.

**Additional equipment:** To order spare parts for additional equipment like side-fitting connection box, micro- or proximity switch, it is necessary to specify the serial number of the brake.

Datum 16.12.2003	erstellt EVA / Thonen	geprüft EVA / Tho	ÄM-Nr. A / 4-Tho03103	<b>a00 594 300-958</b>
---------------------	--------------------------	----------------------	--------------------------	------------------------