

**Spare part list**  
**Electromagnetic Spring-Set-Brake**  
**Series SFB 630**



**Please supply the following details when ordering spare parts:**

- Dimension of the brake (type)
- Brake serial number
- Description of the spare part
- Quantity required
- Id.-No. of the spare part

Type, serial number of the brake and the coil voltage are specified on the rating plate.

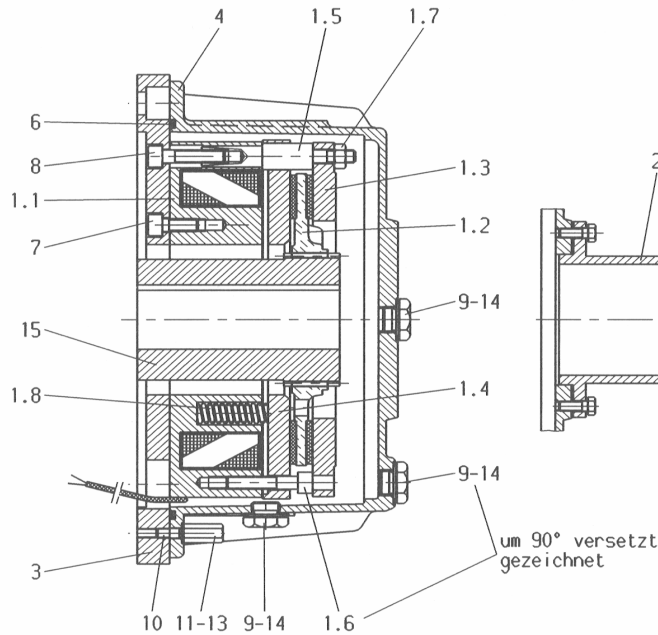

Rating plate

<b>PINTSCH BAMAG</b>		DINSLAKEN	
Bremse/Brake	<input type="text"/>		
Moment/Torque	<input type="text"/>	Nm	
<input type="text"/> V DC	<input type="text"/> A	<input type="text"/> W	
Luftspalt/Airgap	<input type="text"/>	norm	
Airgap	Off	<input type="text"/>	max
Nr./No.	<input type="text"/>		
Baujahr/Built	<input type="text"/>		
Prüfung/Test	<input type="text"/>		
		CE	

)*	pos.	description	qty.	dimension / standard	Kg/piece	P.B. Id.-No.
X	1.1.1	coil body group 110V DC	1	D=600 225x132 110 V DC	225,80	000 590 900-214
X	1.1.2	coil body group		D=600 225x132	225,80	type specific
	1.2	friction lining group	1	D 514/d 160 x 78 32z	13,60	000 591 000-214
	1.3	brake flange	1	D 600/d 378 x 38	40,00	000 591 800-214
X	1.4.1	armature plate	1	D 604/d 225 x 49,3	89,00	000 591 700-214
X	1.4.2	armature plate group f. 1 MS/PS		D 604/d 225 x 49,3	89,00	
X	1.4.3	armature plate group f. 2 MS/PS		D 604/d 225 x 49,3	89,00	
	1.5	bolt	12	D 35 x 225	1,15	000 591 600-214
	1.6	socket head screw	2	M 16 x 80 DIN 912 L.W.		031 411 922-000
	1.7	self-locking hexagon nut	12	VM 24 DIN 980		035 075 793-000
	1.8	pressure spring	49	D 23,7 x 91,8		047 010 023-003
	2.0	cover group	1	D 120 x 65		269 300 004-000
X	3.0.1	adaptor flange	1	standard flange A800	90,00	000 592 200-214
X	3.0.2			special flange		type specific
X	4.0.1	housing	1	D 700 x 301	22,00	000 592 300-214
X	4.0.2			special housing		type specific
	6	O-ring	1	610 x 7		042 572 954-000
	7	socket head screw	4	M 16 x 35 DIN 912		031 411 290-000
	8	socket head screw	12	M 16 x 80 DIN 912		031 410 778-000
	9	lock bolt	6	AM 22 x 1,5 DIN 7604		032 410 214-000
	10	stud	12	M10 x 25 DIN 939		033 070 817-000
	11	cup nut	12	M10 x 36		035 620 959-000
	13	washer	12	A10 x 16 DIN 7603		042 524 046-000
	14	washer	6	A22 x 29 DIN 7603		042 524 088-000
	15.1	hub (pinion)	1	rough drilled D=58	33,00	000 591 500-214
	15.2	hub (pinion)		standard cylindrical		type specific
	16	anti condensation heater	1	230V AC		000 792 200-214

\*): For ordering spare parts marked with X, please specify the serial number of the brake printed on the rating plate.

**Note:** Positions with three digits (f.e. 1.2.3) are possible variants. The installed variant depends on the type of the brake.

**Additional equipment:** To order spare parts for additional equipment like side-fitting connection box, micro- or proximity switch, it is necessary to specify the serial number of the brake.

Datum 16.12.2003	erstellt EVA / Thonen	geprüft EVA / Tho	ÄM-Nr. B / 4-Tho03103	<b>a00 592 500-958</b>
---------------------	--------------------------	----------------------	--------------------------	------------------------