

**Spare part list
Electromagnetic Spring-Set-Brake
Series SFB 40**



Please supply the following details when ordering spare parts:

- Dimension of the brake (type)
- Brake serial number
- Description of the spare part
- Quantity required
- Id.-No. of the spare part

Type, serial number of the brake and the coil voltage are specified on the rating plate.

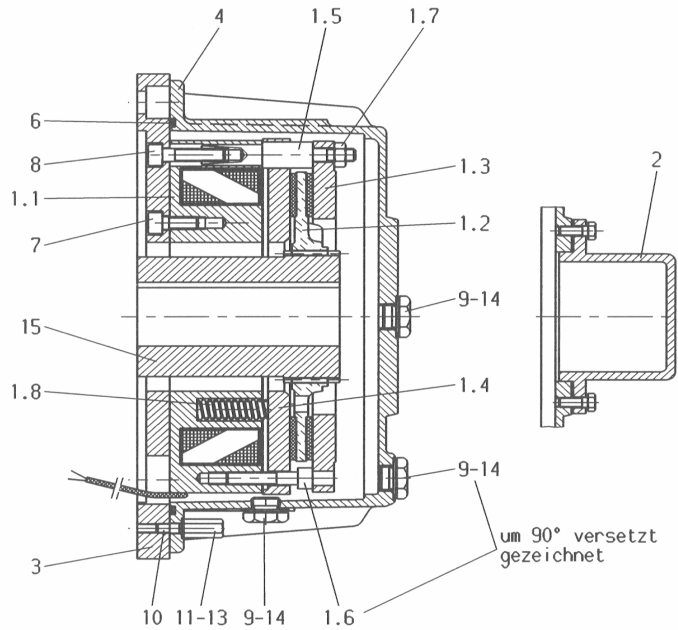

Rating plate

PINTSCH BAMAG	
D I N S L A K E N	
Bremse/Brake	<input type="text"/>
Moment/Torque	<input type="text"/> Nm
<input type="text"/> V DC	<input type="text"/> A <input type="text"/> W
Luftspalt/Airgap	<input type="text"/> norm
Airgap	Off <input type="text"/> max
Nr./No.	<input type="text"/>
Baujahr/Built	<input type="text"/>
Prüfung/Test	<input type="text"/>
CE	

)* pos.	description	qty.	dimension / standard	Kg/piece	P.B. Id.-No.
X 1.1.1	coil body group 110V DC	1	D=280 118 x 62 110 V DC	21,65	000 592 700-214
X 1.1.2	coil body group		D=280 118 x 62	21,65	type specific
1.2	friction lining group	1	D 240/d 85 x 25 18z	1,40	000 592 800-214
1.3	brake flange	1	D 280/d 172 x 16,5	3,80	000 593 600-214
X 1.4.1	armature plate	1	D 283/d 118 x 20,2	7,80	000 593 500-214
X 1.4.2	armature plate group f. 1 MS/PS		D 283/d 118 x 20,2	7,80	001 153 600-214
X 1.4.3	armature plate group f. 2 MS/PS		D 283/d 118 x 20,2	7,80	001 153 601-214
1.5	bolt	6	D 16x 110 M10	0,11	000 593 400-214
1.6	socket head screw	2	M 8 x 40 DIN 912 L.W.		031 411 803-000
1.7	self-locking hexagon nut	6	VM 10 DIN 980		035 075 772-000
1.8	pressure spring	12	D 16 x 71		047 010 016-012
2.0	cover group	1	D 120 x 65		269 300 004-000
X 3.0.1	adaptor flange	1	standard flange A400	16,00	000 593 800-214
X 3.0.2			standard flange A450	23,00	000 593 900-214
X 3.0.3			standard flange A550	34,20	000 594 000-214
X 3.0.4			special flange		type specific
X 4.0.1	housing	1	D 400 x 160	16,00	000 594 100-214
X 4.0.2			special housing		type specific
6	O-ring	1	297 x 4		042 572 639-000
7	socket head screw	4	M 8 x 20 DIN 912		031 411 126-000
8	socket head screw	4	M 8 x 35 DIN 912		031 411 532-000
9	lock bolt	6	AM 16 x 1,5 DIN 7604		032 410 210-000
10	stud	8	M8 x 18 DIN 939		033 020 784-000
11	cup nut	8	M8 x 29		035 620 957-001
13	washer	8	A8 x 14 DIN 7603		042 524 036-000
14	washer	6	A16 x 20 DIN 7603		042 524 064-000
15.1	hub (pinion)	1	rough drilled D=36	5,30	000 593 300-214
15.2	hub (pinion)		standard cylindrical		type specific
16	anti condensation heater	1	230V AC		001 045 000-214

)*: For ordering spare parts marked with X, please specify the serial number of the brake printed on the rating plate.

Note: Positions with three digits (f.e. 1.2.3) are possible variants. The installed variant depends on the type of the brake.

Additional equipment: To order spare parts for additional equipment like side-fitting connection box, micro- or proximity switch, it is necessary to specify the serial number of the brake.

Datum 16.12.2003	erstellt EVA / Thonen	geprüft EVA / Tho	ÄM-Nr. A / 4-Tho03103	a00 590 100-958
---------------------	--------------------------	----------------------	--------------------------	------------------------