

**Spare part list
Electromagnetic Spring-Set-Brake
Series SFB 63**



Please supply the following details when ordering spare parts:

- Dimension of the brake (type)
- Brake serial number
- Description of the spare part
- Quantity required
- Id.-No. of the spare part

Type, serial number of the brake and the coil voltage are specified on the rating plate.

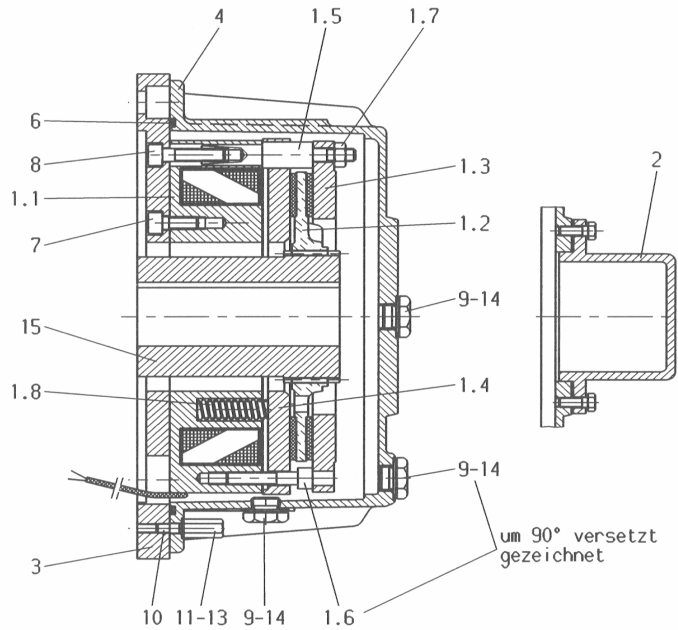

Rating plate

PINTSCH BAMAG		D I N S L A K E N	
Bremse/Brake	[]		
Moment/Torque	[] Nm	[]	
[] V DC	[] A	[] W	[]
Luftspalt/Airgap	[] norm	[]	
Airgap	Off	[] max	[]
Nr./No.	[]		
Baujahr/Built	[]		
Prüfung/Test	[]		
		CE	

)* pos.	description	qty.	dimension / standard	Kg/piece	P.B. Id.-No.
X 1.1.1	coil body group 110V DC	1	D=328 152x65 110 V DC	28,90	000 586 000-214
X 1.1.2	coil body group		D=328 152x65	28,90	type specific
1.2	friction lining group	1	D 282/d 110 x 35 22z	2,00	000 580 300-214
1.3	brake flange	1	D 328/d 200 x 18,5	6,00	000 580 600-214
X 1.4.1	armature plate	1	D 330/d 152 x 20,2	10,00	000 580 500-214
X 1.4.2	armature plate group f. 1 MS/PS		D 330/d 152 x 20,2	10,00	001 157 100-214
X 1.4.3	armature plate group f. 2 MS/PS		D 330/d 152 x 20,2	10,00	
1.5	bolt	6	D 18x 112	0,14	000 581 100-214
1.6	socket head screw	2	M 8 x 40 DIN 912 L.W.		031 411 803-000
1.7	self-locking hexagon nut	6	VM 12 DIN 980		035 075 775-000
1.8	pressure spring	16	D 16 x 71		047 010 016-012
2.0	cover group	1	D 120 x 65		269 300 004-000
X 3.0.1	adaptor flange	1	standard flange A450	21,00	000 583 300-214
X 3.0.2			standard flange A550	34,00	000 583 400-214
X 3.0.3			standard flange A660	61,20	000 666 300-214
X 3.0.4			special flange		type specific
X 4.0.1	housing	1	D 440 x 162	22,00	000 580 400-214
X 4.0.2			special housing		type specific
6	O-ring	1	355 x 4		042 572 753-000
7	socket head screw	3	M 10 x 20 DIN 912		031 411 162-000
8	socket head screw	6	M 10 x 40 DIN 912-8.8-A3G		031 411 170-000
9	lock bolt	6	AM 16 x 1,5 DIN 7604 Ms		032 410 210-000
10	stud	8	M8 x 18 DIN 939-8.8-A3G		033 020 784-000
11	cup nut	8	M8 x 29 Ms		035 620 957-001
13	washer	8	A8 x 14 DIN 7603-Cu		042 524 036-000
14	washer	6	A16 x 20 DIN 7603-Cu		042 524 064-000
15.1	hub (pinion)	1	rough drilled D=36	9,00	000 586 100-214
15.2	hub (pinion)		standard cylindrical		type specific
16	anti condensation heater	1	230V AC		000 799 500-214

)*: For ordering spare parts marked with X, please specify the serial number of the brake printed on the rating plate.

Note: Positions with three digits (f.e. 1.2.3) are possible variants. The installed variant depends on the type of the brake.

Additional equipment: To order spare parts for additional equipment like side-fitting connection box, micro- or proximity switch, it is necessary to specify the serial number of the brake.

Datum 16.12.2003	erstellt EVA / Thonen	geprüft EVA / Tho	ÄM-Nr. A / 4-Tho03103	a00 585 900-958
---------------------	--------------------------	----------------------	--------------------------	------------------------