

Spare part list
Electromagnetic Spring-Set-Brake
Series SFB 250



Please supply the following details when ordering spare parts:

- Dimension of the brake (type)
- Brake serial number
- Description of the spare part
- Quantity required
- Id.-No. of the spare part

Type, serial number of the brake and the coil voltage are specified on the rating plate.

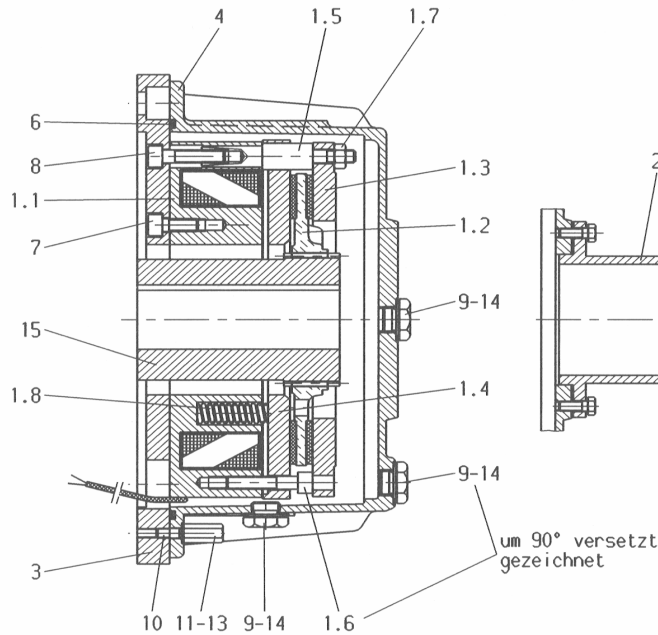

Rating plate

PINTSCH BAMAG	
DINSLAKEN	
Bremse/Brake	<input type="text"/>
Moment/Torque	<input type="text"/> Nm
<input type="text"/> V DC	<input type="text"/> A <input type="text"/> W
Luftspalt/Airgap	<input type="text"/> norm
Airgap	Off <input type="text"/> max
Nr./No.	<input type="text"/>
Baujahr/Built	<input type="text"/>
Prüfung/Test	<input type="text"/>

)*	pos.	description	qty.	dimension / standard	Kg/piece	P.B. Id.-No.
X	1.1.1	coil body group 110V DC	1	D=470 195x94,7 110 V DC	92,50	000 579 700-214
X	1.1.2	coil body group		D=470 195x94,7	92,50	type specific
	1.2	friction lining group	1	D 406/d 140 x 50 28z	7,00	000 584 200-214
	1.3	brake flange	1	D 470/d 290 x 27	19,00	000 584 500-214
X	1.4.1	armature plate	1	D 476/d 195 x 35,3	39,00	000 584 400-214
X	1.4.2	armature plate group f. 1 MS/PS		D 476/d 195 x 35,3	39,00	type specific
X	1.4.3	armature plate group f. 2 MS/PS		D 476/d 195 x 35,3	39,00	type specific
	1.5	bolt	8	D 26 x 156 M16	0,44	000 584 700-214
	1.6	socket head screw	2	M 12 x 65 DIN 912 L.W.		031 411 879-000
	1.7	self-locking hexagon nut	8	VM 16 DIN 980		035 075 781-000
	1.8	pressure spring	24	D 23,7 x 91,8		047 010 023-003
	2.0	cover group	1	D 120 x 65		269 300 004-000
X	3.0.1	adaptor flange	1	standard flange A660	61,00	000 579 200-214
X	3.0.2			standard flange A800	90,30	000 579 300-214
X	3.0.3			special flange		type specific
X	4.0.1	housing	1	D 556 x 223	49,00	000 584 300-214
X	4.0.2			special housing		type specific
	6	O-ring	1	490 x 5		042 572 930-000
	7	socket head screw	4	M 12 x 25 DIN 912		031 411 202-000
	8	socket head screw	8	M 12 x 70 DIN 912		031 411 620-000
	9	lock bolt	6	AM 16 x 1,5 DIN 7604		032 410 210-000
	10	stud	8	M10 x 25 DIN 939		033 070 817-000
	11	cup nut	8	M10 x 36		035 620 959-000
	13	washer	8	A10 x 16 DIN 7603		042 524 046-000
	14	washer	6	A16 x 20 DIN 7603		042 524 064-000
	15.1	hub (pinion)	1	rough drilled D=46	21,00	000 585 200-214
	15.2	hub (pinion)		standard cylindrical		type specific
	16	anti condensation heater	1	230V AC		001 043 700-214

)*: For ordering spare parts marked with X, please specify the serial number of the brake printed on the rating plate.

Note: Positions with three digits (f.e. 1.2.3) are possible variants. The installed variant depends on the type of the brake.

Additional equipment: To order spare parts for additional equipment like side-fitting connection box, micro- or proximity switch, it is necessary to specify the serial number of the brake.

Datum 16.12.2003	erstellt EVA / Thonen	geprüft EVA / Tho	ÄM-Nr. A / 4-Tho03103	a00 579 600-958
---------------------	--------------------------	----------------------	--------------------------	------------------------